

TechBook

in.touch 3 & 3+

Control your spa from anywhere



Connectivity device for spa remote control



Table of contents

1. Warning	4
2. Introduction	6
3. Accessory Kit	8
4. Installation of the in.touch 3 & 3+ module	9
5. Troubleshooting	10
· Home Transmitter (EN Module) LED status	10
· Spa Transmitter (CO Module) LED status	10
· Pairing the Spa Transmitter (CO Module) and the Home Transmitter (EN Module)	11
· Water Acquisition (CO Module) button and LED status (Currently in Development)	12
6. Specifications	13
· Technical Specifications	13
· Environmental conditions for optimal operation	13
· List of compatible devices and systems	13

1. Warning



WARNING:

Before installing or connecting the unit, please read the following.

- * INSTALL THE IN.TOUCH 3-CO MODULE AT LEAST 12" (30 CM) AWAY FROM ANY METAL PART OR ANY METAL FOIL.
- * THE IN.TOUCH 3-CO MODULE SHOULD BE INSTALLED SUCH AS IT CAN BE RELOCATED UNDER THE SPA IN ORDER TO OBTAIN OPTIMAL RECEPTION AFTER FINAL INSTALLATION OF THE SPA IN THE YARD.
- * TO SATISFY FCC RF EXPOSURE REQUIREMENTS FOR MOBILE AND BASE STATION TRANSMISSION DEVICES, A SEPARATION DISTANCE OF 8" (20 CM) OR MORE SHOULD BE MAINTAINED BETWEEN THE IN.TOUCH 3 MODULES AND PERSONS DURING OPERATION; TO ENSURE COMPLIANCE, OPERATION AT CLOSER THAN THIS DISTANCE IS NOT RECOMMENDED.
- * THE ANTENNAS USED FOR THESE MODULES MUST NOT BE CO-LOCATED OR OPERATING IN CONJUNCTION WITH ANY OTHER ANTENNA OR TRANSMITTER.
- * TO POWER THE IN.TOUCH 3-EN, USE THE POWER SUPPLY UNIT PROVIDED WITH THE IN.TOUCH 3-EN.

CAUTION: TO REDUCE THE RISK OF ELECTRIC SHOCK, DO NOT DISMANTLE THE UNIT. THERE ARE NO USER SERVICEABLE PART INSIDE. REFER SERVICING TO QUALIFIED SERVICE PERSONNEL

IMPORTANT SAFETY INSTRUCTION: FOR YOUR OWN SAFETY PLEASE READ THE FOLLOWING IMPORTANT SAFETY INSTRUCTION CAREFULLY BEFORE ATTEMPTING TO CONNECT THIS UNIT TO THE MAIN POWER SUPPLY. THEY WILL ALSO ALLOW YOU TO GET THE BEST PERFORMANCE AND PROLONG THE LIFE OF THE UNIT.

- * READ THESE INSTRUCTIONS.
- * CLEAN ONLY WITH DRY CLOTH. BEWARE THE APPLICATION OF SOME PRODUCTS COMMONLY USED AGAINST CORROSION (SUCH AS WD-40 FAMILY PRODUCTS) AS THEY COULD DAMAGE THE ENCLOSURE, DUE TO A NEGATIVE CHEMICAL REACTION BETWEEN SOME INDUSTRIAL OILS AND ITS PLASTIC ENCLOSURE. ANY OTHER MATERIALS WHICH MAY COME IN CONTACT WITH THE ENCLOSURE MUST BE CAREFULLY EVALUATED UNDER END USE CONDITIONS FOR COMPATIBILITY.
- * DO NOT INSTALL NEAR ANY HEAT SOURCES.
- * ONLY USE ATTACHMENTS/ACCESSORIES SPECIFIED BY THE MANUFACTURER.
- * REFER ALL SERVICING TO QUALIFIED SERVICE PERSONNEL. SERVICING IS REQUIRED WHEN THE APPARATUS HAS BEEN DAMAGED IN ANY WAY, SUCH AS POWER-SUPPLY CORD OR PLUG IS DAMAGED, LIQUID HAS BEEN SPILLED OR OBJECTS HAVE FALLEN INTO THE APPARATUS, DOES NOT OPERATE NORMALLY, OR HAS BEEN DROPPED

WARNINGS: Before installing or connecting the unit, please read the following

- * DO NOT DISASSEMBLE OR ALTER THE APPARATUS
- * DO NOT USE FOAM TO ISOLATE THE UNIT
- * TURN POWER OFF BEFORE MODIFYING ANY CABLE CONNECTION IN THIS UNIT
- * TURN POWER OFF BEFORE CLEANING OR SERVICING THIS UNIT
- * PRODUCT MUST BE DISPOSED OF SEPARATELY FROM NORMAL HOUSEHOLD IN ACCORDANCE WITH LOCAL WASTE DISPOSAL LEGISLATION
- * DO NOT SERVICE THIS PRODUCT YOURSELF
- * ANY DAMAGED CABLE MUST BE IMMEDIATELY REPLACED BY QUALIFIED PERSONNEL.
- * THESE PRODUCTS MUST NOT BE INSTALLED IN PROXIMITY OF HIGHLY FLAMMABLE MATERIALS.
- * IMPROPER WIRING MAY CAUSE DAMAGE TO THIS CONTROL SYSTEM. READ AND FOLLOW ALL WIRING INSTRUCTIONS WHEN CONNECTING TO POWER SUPPLY.
- * PRODUCT MUST BE DISPOSED OF SEPARATELY IN ACCORDANCE WITH LOCAL WASTE DISPOSAL LEGISLATION.
- * THIS APPLIANCE IS NOT INTENDED FOR USE BY PERSONS (INCLUDING CHILDREN) WITH REDUCED PHYSICAL, SENSORY OR MENTAL CAPABILITIES, OR LACK OF EXPERIENCE AND KNOWLEDGE, UNLESS THEY HAVE BEEN GIVEN SUPERVISION OR INSTRUCTION CONCERNING USE OF THE APPLIANCE BY A PERSON RESPONSIBLE FOR THEIR SAFETY.
- * CHILDREN SHOULD BE SUPERVISED TO ENSURE THAT THEY DO NOT PLAY WITH THE APPLIANCE.

-
-
- * MEANS FOR DISCONNECTION MUST BE INCORPORATED IN THE FIXED WIRING IN ACCORDANCE WITH THE WIRING RULES.
 - * PARTS INCORPORATING ELECTRICAL COMPONENTS, EXCEPT REMOTE CONTROL DEVICES, MUST BE LOCATED OR FIXED SO THAT THEY CANNOT FALL INTO THE BATH OR SPA.
 - * PARTS ARE TO BE INSTALLED IN THE CORRECT ZONE AND EQUIPOTENTIAL BONDING CARRIED-OUT IN ACCORDANCE WITH THE WIRING RULES.
 - * CLEARANCE AND MINIMUM DISTANCE BETWEEN THE VARIOUS PARTS OF THE APPLIANCE AND THE SURROUNDING STRUCTURE ARE NOT SPECIFIED AS LONG AS THEY ARE SUFFICIENT SO THAT THE AMBIENT TEMPERATURE AROUND THE CONTROLLER DOES NOT EXCEED 60°

DISPOSAL OF THE PRODUCT

THE APPLIANCE (OR THE PRODUCT) MUST BE DISPOSED OF SEPARATELY IN ACCORDANCE WITH THE LOCAL WASTE DISPOSAL LEGISLATION IN FORCE.



COMPATIBILITY REQUIREMENTS

in.touch 3 & 3+ modules for FCC (North America) models (915 MHz):

in.touch 3 & 3+ modules for ETSI (Europe) models (868 MHz):

The in.touch 3 & 3+ are compatible with the following spa controllers (spa packs): in.yj, in.ye, and in.yt, versions 2 and higher.

Note: The spa pack name (in.yj, in.ye, in.yt) and version (V2, V3, etc.) can be found on the ID label attached to the front cover of the spa pack. The spa pack version is located in the "Options" section of the ID label, and the name is in the "Model" section.

in.touch 3 & 3+ application:

Compatible with devices running: iOS 8.0 or higher Android 2.3 or higher

ROUTER AND INSTALLATION REQUIREMENTS

Any standard router with an available 100 Mbps (wired LAN) RJ45 port can be used. The router must also have its Port 10022 open, which is normally a default setting. A 3-foot (0.9 m) Ethernet cable is included.

The home transmitter will need a main supply (120V in North America, 220V in Europe) nearby to allow connection of the transformer.

2. Introduction



Mobile remote control

Turn your smartphone into a spa controller to adjust the temperature without walking to the spa.

Continuous improvement

Stay ahead with regular system updates tailored to new products, ensuring your spa feels refreshed with every release.

Reliable connectivity

Proven radio frequency (RF) communication between both modules allows for strong, stable and long-range signal between spa and router.

3. Accessory Kit

in.touch 3
spa connectivity only

in.touch 3+
connectivity and water monitoring

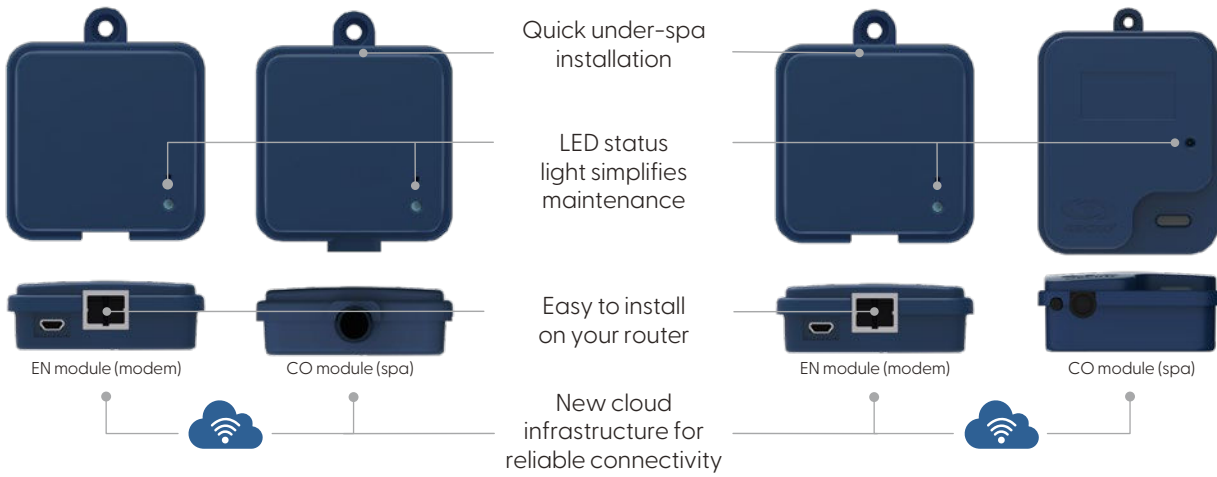

in.touch 3 & 3+ (EN module)

in.touch 3 (CO module)

in.touch 3+ (CO module)

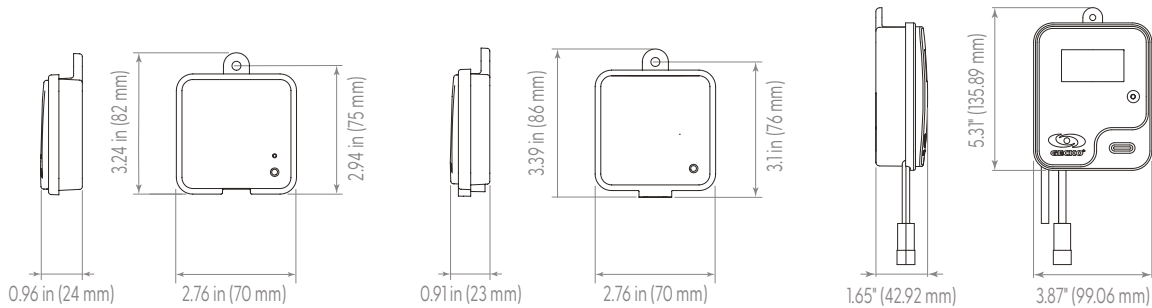

Compare

	in.touch 2	in.touch 3	in.touch 3+
Enable remote spa control	Yes	Yes	Yes
Over-the-air updates	No	Yes	Yes
Integrate with Gecko waterlab for 24/7 water monitoring	No	No	Yes
CO module (spa) dimensions (in)	86 x 70 x 23	86 x 70 x 23	136 x 99 x 43
EN module (modem) dimensions (in)	82 x 70 x 24	82 x 70 x 24	82 x 70 x 24

4. Installation of the in.touch 3 & 3+ module

CO module (Spa) installation



Prior to any installation procedures, turn off the power of the spa

Install the CO module unit under the hot tub skirt as high as possible in a corner facing towards your home router.

The CO module should be at least 12" (30 cm) from any metal component or structure.

This is necessary to ensure optimal transmission. In some cases, it may be necessary to relocate the unit once the spa is installed in the yard to guarantee proper signal transmission and distance.



Screw the CO module with a # 8 pan head screw and leave some slack on the cable

This will enable the module to be repositioned to optimize the signal strength in the yard.

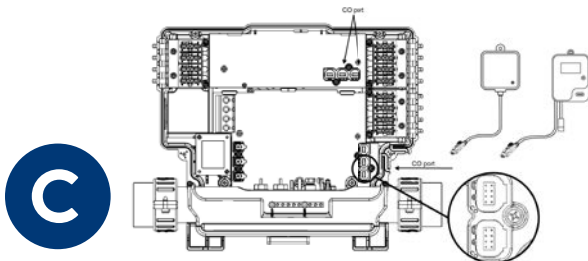

Connect the CO module into an available CO port of the control system

Note that the CO module only has a single CO cable and must be installed at the end of the CO chain if more than a single accessory is installed on the same CO port of the control system.

EN (Home) installation

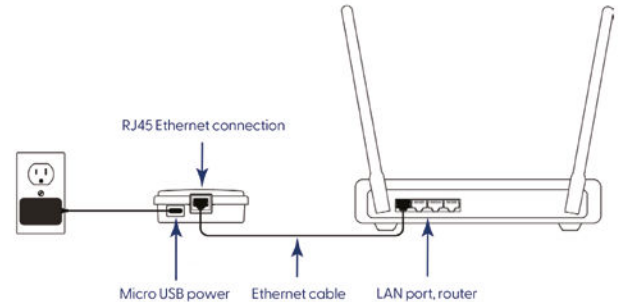

To allow communication between the CO and EN module, the EN module needs to be installed on a router.



1 Connect the power supply of the CO module.



2 Connect your home router to the EN module using the LAN port with the ethernet cable.

5. Troubleshooting

The product consists of a total of three LEDs representing the three main boards present within the product. The Home Transmitter board (contained within the EN Module), the Spa Transmitter board (contained within the CO Module) and the Water Monitoring board (contained within the CO module). The CO and EN module communicate together via an RF link while the Water monitoring board communicates directly to the CO transmitter board since they are both contained within the CO module. The Home Transmitter is responsible for the Ethernet communications, the Spa Transmitter is responsible for the spa communications and the Water Monitoring board is responsible for acquisition of water sampling.

Home Transmitter (EN Module) LED status

This module's LED can show various status conditions, as indicated below.

Rapidly flashing YELLOW color:

The Home Transmitter is in pairing mode when this color is shown (the pairing switch was pressed). Until a pairing successfully completes, the application cannot connect to the spa. To complete the pairing, you must turn off the spa (using its breaker), wait a few seconds and then flip back the breaker to on. The pairing will then occur within a few seconds. If not, then the Spa Transmitter is either incorrectly connected, out of range, or defective.

If the in.touch 3 modules were previously paired and the pairing switch is accidentally pressed, simply unplug the Home Transmitter USB power cord and re-plug it (thereby resetting the Home Transmitter). The modules should then normally reconnect together.

Once out of pairing mode, the Home Transmitter will display another color.

For each of the following colors, the information applies whether the LED is blinking or not. If the LED is blinking, please also refer to the Blinking LED section below.

RED color:

The Home Transmitter is not detecting a router. Until this is resolved, the application cannot connect to the spa.

Make sure the router is powered and working correctly (i.e. test it using another computer or device connected to the same LAN port you intend to use). Make sure the Ethernet cable is correctly

connected at each end (LAN port on router end, and the Home Transmitter.) If the problem still occurs, try connecting with another cable. If a computer (or other device) works fine on the LAN port, and the cable is fine, then the home transmitter is likely defective.

GREEN color:

The Home Transmitter is connected to a router (an IP address was assigned), but the in.touch 3 server is not reachable.

This is very likely a router configuration issue, so refer to your router's User Manual. It may be due to Port 10022 being closed. Normally, this port is open by default in commercial routers, but different routers may have different behaviors.

If Port 10022 is confirmed as open, then some other internal configuration is preventing the router from accessing Internet. The server may also simply be temporarily "offline" for servicing/maintenance, so try again later. The problem can also be due to the Internet connection (WAN), a router misconfiguration, or your Internet Service Provider (ISP) has issues with its network connection.

BLUE color:

This is the normal state of the Home Transmitter LED. It has a full Internet connection, with access to the in.touch 3 server. If your device and application have access to the Internet (either via Wi-Fi or cellular data such as 3G, 4G, or LTE), then you're good to go!

Spa Transmitter (CO Module) LED status

This module's LED can show various status conditions, as shown below.

Rapidly flashing YELLOW color:

The Spa Transmitter is in pairing mode when this color is shown. This normally briefly occurs automatically during power-up of the spa (i.e. right after the breaker is flipped on). This could also occur if the Spa Transmitter was never paired (which is very unlikely, as they are shipped paired from factory). Refer to the pairing section below if your unit has not been paired, so you may complete the process.

BLUE color:

This is the normal state of the Spa Transmitter LED. If the Spa Transmitter also shows solid blue, you are all set! If this LED is blinking, refer to the Blinking LED section below.

Blinking LED:

On both modules, if the LED is blinking about once per second, it means that the RF link is not established between them (i.e. each in.touch 3 module cannot communicate with its counterpart). This can occur for several reasons.

Review the following and perform the tests in the order given below:

Unpaired:

As the modules are shipped paired from the factory, this is not a likely cause, but it is the easiest test to perform in the field. Simply attempt to pair them again. Please refer to the Pairing section for instructions on pairing below.

Modules out of range:

If the pairing test above does not resolve the problem, then the modules may be too far from each other for an effective RF link. To test this, simply connect the Home Transmitter outside, close to the spa (via an extension cord for power).

A router connection is not needed for this test. If the module LEDs no longer blink, an RF link was established which confirms the hypothesis that the modules were too far apart. Getting the modules closer together somehow is the only solution. If moving the modules closer together does not stop the LEDs from blinking, attempt to pair them again. If this pairing fails even though the RF modules are near each other, then one or both modules are defective, replace them.

Pairing the Spa Transmitter (CO Module) and the Home Transmitter (EN Module)

The pairing process is used when you need to replace one module of the in.touch 3 kit. Otherwise, the in.touch 3 arrives pre-paired from the factory.

- 1) Power up the Home Transmitter

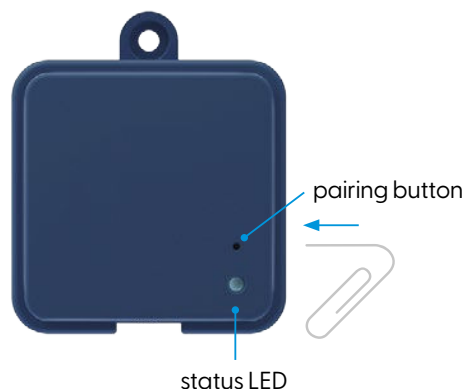

- 2) Press on the pairing button with a paper clip or some similar tool. When the pairing mode is active the status LED flashes YELLOW in a rapid pattern. The Home Transmitter is then in pairing mode and will remain in this mode until it pairs with an Spa Transmitter, or until it is reset (power cycled).
- 3) Shut off the spa's breaker (thus turning off the Spa Transmitter), wait a few seconds, and then flip the breaker back on. Within a few seconds, the pairing operation should complete, and the Home Transmitter status LED will no longer be YELLOW.

NOTE: in.touch 3 modules can be paired as often as necessary, but can only be paired with a single counterpart module at a time. Once paired, the modules store this information permanently until the next pairing operation. Pairing information is stored in non-volatile memory, so pairing is not required after a power failure. Only a Home Transmitter can initiate a pairing, so it is important that the pairing begin with putting the home transmitter module in pairing mode. If several spas are powered up at the same time with a Home Transmitter in pairing mode (for instance, in a dealer showroom), only the 1st spa to successfully connect to the Home Module will pair. As this can be random, it is recommended that only 1 spa be powered up at a time during the pairing process.

Water Acquisition (CO Module) button and LED status (currently in development)



The CO module of the in.touch 3+ also contains a button with a visible LED status. The main purpose of the LED is to identify the status of the Gecko waterlab probe or as mentioned in the application section, enter specified modes such as calibration mode or take on demand samples.

LED Button troubleshooting

Blinking blue LED

This is the normal state of the Water Acquisition button. If both the CO and EN modules show solid blue, you are all set! For any other colors or patterns, refer below for troubleshooting.

Full red LED (in development)

A solid red color would indicate that there is no probe connected to the CO module. As such, it is currently impossible to acquire any water chemistry data. Please verify if a probe is present and/or if it is connected to the in.touch 3 CO module.

Full Yellow Light (in development)

A yellow light would indicate that physical connection has been established with the probe, but this probe has not yet been identified/associated. This behaviour is normal once the prob is received as the association of the probe is done through the setup flow on the in.touch 3 app. Please refer to the in.touch 3 app for more details on the setup flow

Full Purple Light (in development)

A full purple light is an indication that there was an issue with the latest updates which resulted in a firmware error. Therefore, the connection between the water characterisation board and the CO board may be disrupted. To revert the firmware to its last firmware, the LED button must be long pressed (5 seconds). The LED status light should then start blinking purple at a frequency of about 2 blinks per second. The process of reverting back to the last update may take up to several minutes.

6. Specifications

Technical Specifications

Weight

in.touch 3 module: 320.5g

EN module: 63.5g

Environmental conditions for optimal operation

in.touch

Operating temperature: -4°F (-20°C) to 140°F (60°C)

Storage temperature: -22°F (-30°C) to 185°F (85°C)

Humidity: Up to 85% noncondensing

Level of waterproofing: IPX5



9919-100890-A
Rev. 11-2024

© Groupe Gecko Alliance inc., 2024
All trademarks or registered trademarks
are the property of their respective owners.

Gecko Alliance
450 des Canetons, Québec (Qc), G2E 5W6 Canada, 1.800.78.GECKO
www.geckoalliance.com